

101 IX

INOX

Dobradiça em chapa de duas abas - anilhas em latão

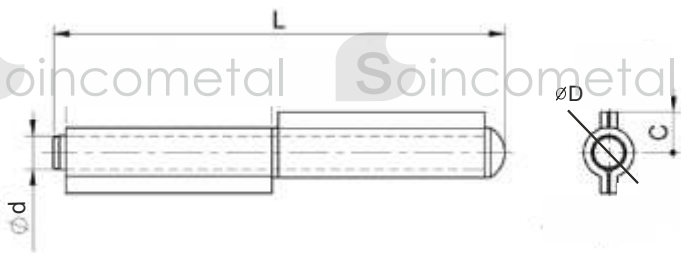

| Referência | L | D | d | C | Qt p/caixa |
|-------------|-----|----|-----|------|------------|
| 101 IX/80 | 83 | 12 | Ø8 | 10 | 24 |
| 101 IX/100 | 102 | 13 | Ø9 | 11,5 | 12 |
| 101 IX/120 | 124 | 14 | Ø10 | 12 | 12 |
| 101 IX/ 140 | 144 | 16 | Ø11 | 13 | 12 |

106 IX

Dobradiça em chapa de três abas - anilhas em latão

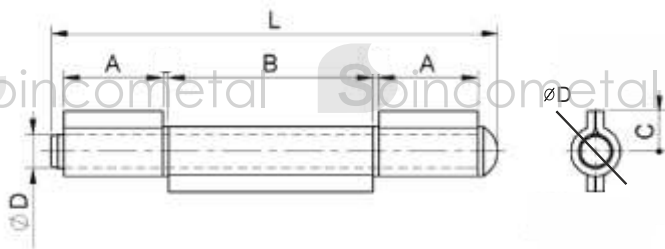

| Referência | L | D | d | A | B | C | Qt p/caixa |
|-------------|-----|----|-----|----|----|------|------------|
| 106 IX/80 | 83 | 12 | Ø8 | 17 | 36 | 10 | 24 |
| 106 IX/100 | 102 | 13 | Ø9 | 22 | 46 | 11,5 | 12 |
| 106 IX/120 | 124 | 14 | Ø10 | 27 | 56 | 12 | 12 |
| 106 IX/ 140 | 144 | 16 | Ø11 | 32 | 66 | 13 | 12 |

109 IX

Dobradiça em chapa de duas abas c/ topos - anilhas em latão

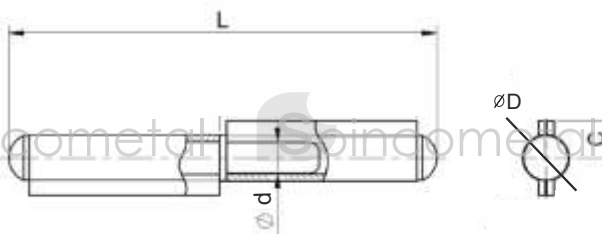

| Referência | L | D | d | C | Qt p/caixa |
|-------------|-----|----|----|------|------------|
| 109 IX/80 | 84 | 12 | 8 | 10 | 24 |
| 109 IX/100 | 105 | 13 | 9 | 11,5 | 12 |
| 109 IX/120 | 126 | 14 | 10 | 12 | 12 |
| 109 IX/ 140 | 149 | 16 | 11 | 13 | 12 |

415

INOX

Dobradiça forte em chapa de três abas - anilhas em inox

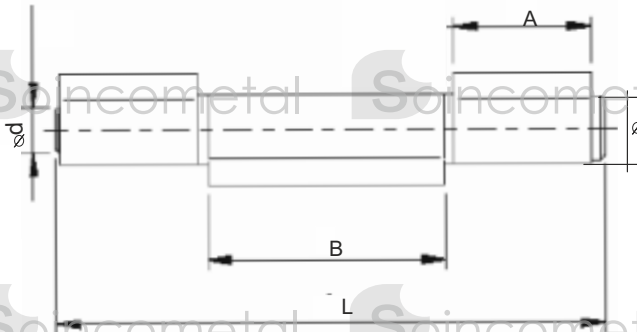

| Referência | L | D | d | A | B | Qt p/caixa |
|------------|-----|----|------|----|----|------------|
| 415/170 IN | 174 | 18 | 11,7 | 44 | 75 | 10 |
| 415/200 IN | 205 | 20 | 13,6 | 52 | 89 | 10 |

456

Dobradiça forte em chapa de duas abas abertas c/ lubrificação - anilha em latão

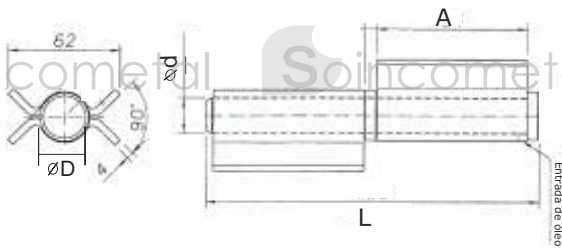

| Referência | L | D | d | Qt p/caixa |
|------------|-----|----|------|------------|
| 456/180 IN | 186 | 28 | 19,8 | 4 |

458

Dobradiça forte em chapa duas abas c/lubrificação - anilha em latão

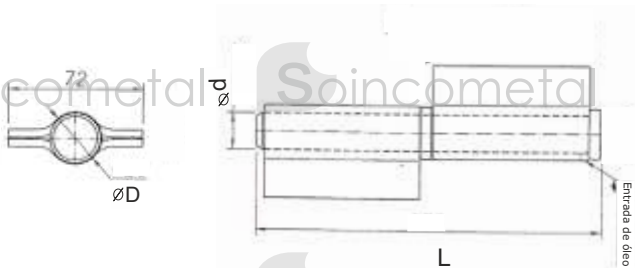

| Referência | L | D | d | Qt p/caixa |
|------------|-----|----|------|------------|
| 458/180 IN | 186 | 28 | 19,8 | 4 |

470 IN

INOX

Dobradiça forte em chapa de três abas
c/lubrificação - anilhas em latão

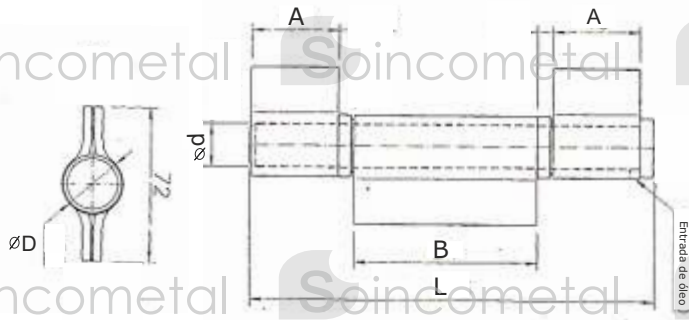

| Referência | L | D | d | A | B | Qt p/caixa |
|------------|-----|----|-------|----|----|------------|
| 470 IN | 186 | 28 | Ø19,8 | 40 | 84 | 4 |

485 IN

Dobradiça forte em chapa de quatro abas
c/lubrificação - anilhas em latão

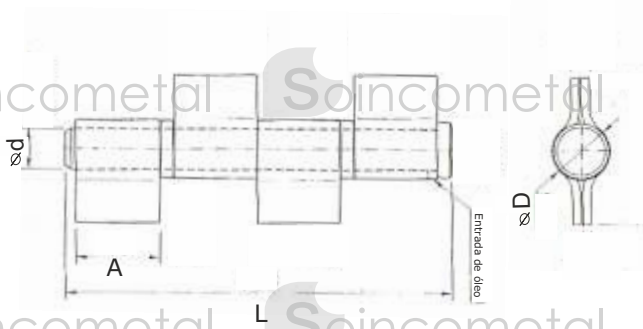

| Referência | L | D | d | Qt p/caixa |
|------------|-----|----|------|------------|
| 485 IN | 186 | 28 | 19,8 | 4 |

114 IX

Anilhas rolamento em latão para dobradiça

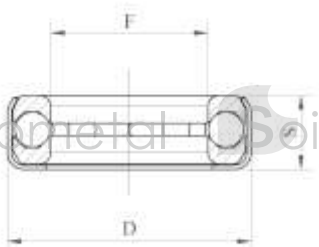

| Referência | F | D | S | Peso suportado | Qt p/caixa |
|------------|-----|-----|-----|----------------|------------|
| 114 IX/10 | Ø10 | Ø18 | 6,3 | 120kg | 20 |
| 114 IX/12 | Ø12 | Ø20 | 6,5 | 140kg | 20 |
| 114 IX/14 | Ø14 | Ø22 | 6,8 | 200kg | 20 |

C IN

INOX

Dobradiça ajustável para soldar

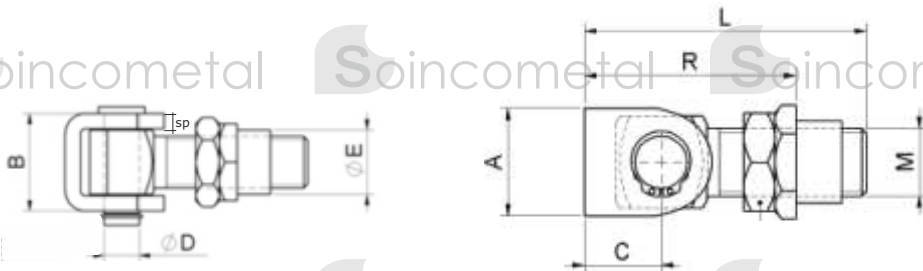

| Referência | A | B | C | D Ø | E Ø | L | SP | M | R | Qt p/caixa |
|------------|----|----|----|--------|--------|----|----|-----|-------|------------|
| C 16 IN | 27 | 35 | 22 | 12 | 23 | 78 | 5 | M16 | 53-66 | 4 |
| C 20 IN | 30 | 39 | 22 | 14 | 25 | 94 | 6 | M20 | 56-81 | 4 |

PG S IN

Pivot superior c/ rolamento e perno giratório

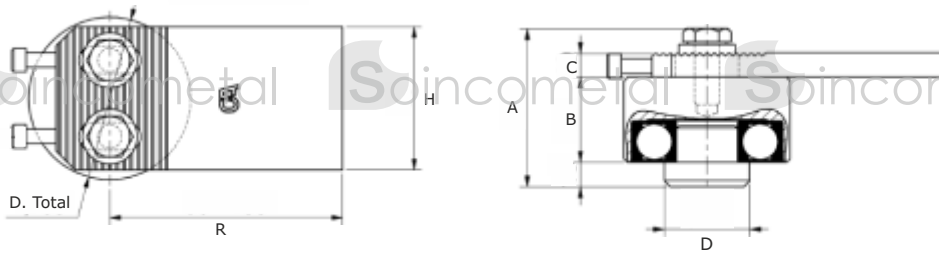

| Referência | A | B | C | D Ø | D.total | H | R | Qt.p/caixa |
|------------|----|----|----|--------|---------|----|--------|------------|
| PG 50 S IN | 62 | 35 | 8 | 30 | 50 | 50 | 72-82 | 4 |
| PG 70 S IN | 65 | 35 | 10 | 35 | 68 | 60 | 90-105 | 4 |

PG I IN

Pivot inferior c/rolamento cônico e grasser

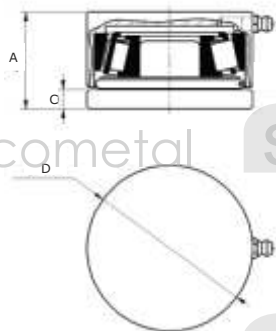

| Referência | A | C | D Ø | Peso suportado | Qt p/caixa |
|------------|----|---|--------|----------------|------------|
| PG 50 I IN | 34 | 7 | 50 | 1000 kg | 4 |
| PG 70 I IN | 40 | 8 | 68 | 2500 kg | 4 |

348 IN

INOX

Perno para pivot

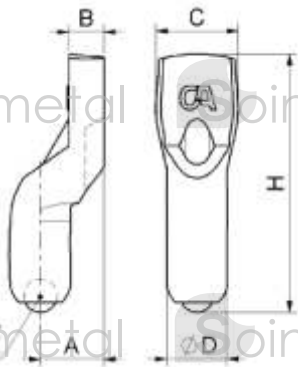

| Referência | A | B | C | D | H | Qt p/caixa |
|------------|----|----|----|-----|----|------------|
| 348/20 IN | 18 | 10 | 30 | Ø20 | 89 | 4 |
| 348/24 IN | 22 | 12 | 32 | Ø23 | 98 | 4 |

349 IN

Placa para pivot



| Referência | A | B | C | D | Qt p/caixa |
|------------|----|----|----|-----|------------|
| 349/20 IN | 50 | 50 | 15 | Ø20 | 4 |
| 349/24 IN | 60 | 60 | 20 | Ø23 | 4 |

165 IN

Tope para tubo quadrado

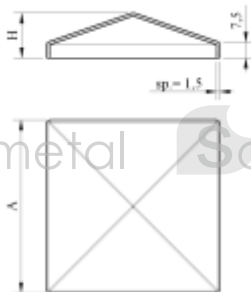

| Referência | A | H | Qt p/caixa |
|------------|----|----|------------|
| 165 50 IN | 51 | 17 | 20 |
| 165 60 IN | 61 | 20 | 20 |
| 165 80 IN | 81 | 22 | 20 |

300 IX

INOX

Fecho de Segunda folha articulado

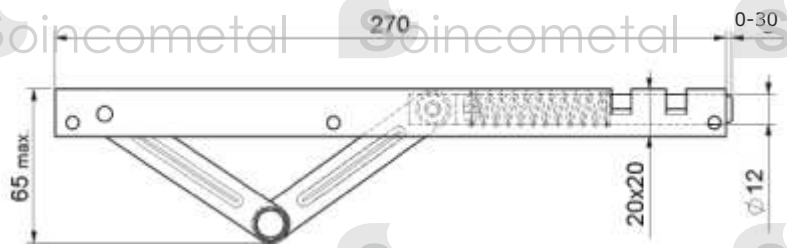

| Referência | Qt p/caixa |
|------------|------------|
| 300 IX | 2 |

301 IX

Fecho de Segunda folha de bola

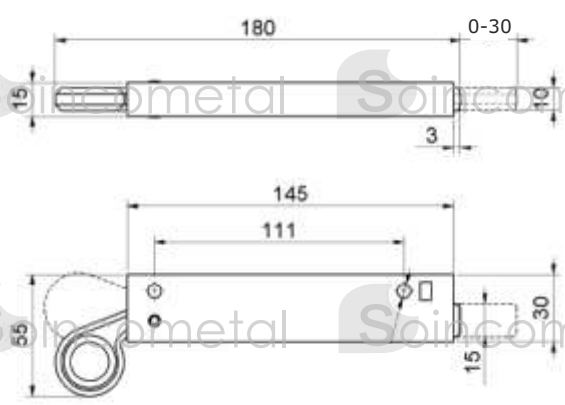

Latão —



| Referência | Qt p/caixa |
|------------|------------|
| 301 IX | 2 |

230 IX

Fecho interior com chave de quadra

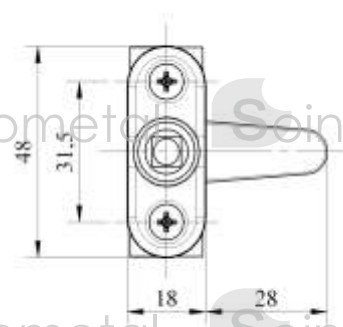

| Referência | Qt p/caixa |
|------------|------------|
| 230 IX | 6 |

Preços sujeitos a alteração sem aviso prévio
Os preços entendem-se à saída do nosso armazém e são acrescidos de IVA